

AF 0005

SEMI AUTOMATIC LIQUID FILLING MACHINE

The AF 0005 Vacuum filler offers small to medium scale filling operations with unparalleled flexibility for filling a wide range of products into rigid containers. The AF 0005 fills to a constant level.



MACHINE FEATURES

- Fills free flowing liquids.
- Accurate dispensing with excellent repeatability.
- Range of nozzles to suit a range of containers.
- Stepper motor drive for fast and accurate labelling.
- Opaque label detection as standard.
- Contact parts manufactured from food grade plastics.
- Tool free removable product contact parts for fast product change over.
- Optional wander nozzle for vial filling.
- Pneumatic nozzle suitable for hazardous products.
- Constructed in compliance with FDA approved materials.
- Optional full IQ/OQ Validation support package.
- Small machine footprint.

YOUR PARTNER IN PACKAGING

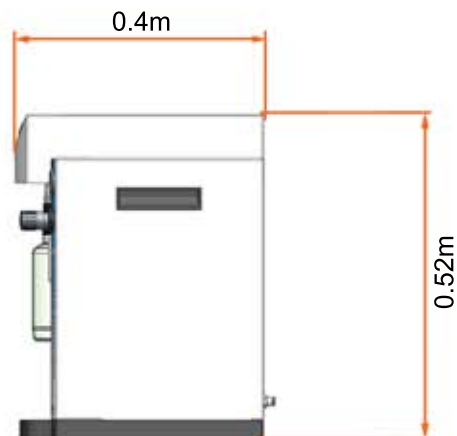
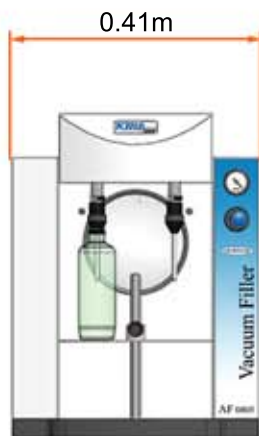

TECHNICAL SPECIFICATION

Filling Range:	2ml - 1L (bottle size dependent).
Filling Accuracy:	+/- 1ml.
Filling Speed:	Operator(s) Dependent.
Filling Technology:	Vacuum
Pneumatic Component Build:	Festo
Vacuum Component Build:	PIAB
Build Standard:	cGMP, CE marked in accordance with Machinery Directive 2006/42/EC
Air Filtration Requirements:	20 Microns (minimum)
Air Supply:	3 - 6 Bar, filtered and dried
Nett Weight:	15Kg

OPERATION

The AF 0005 is operated using a simple control panel where the product flow rate can be adjusted by means of an air regulator. The fill level is controlled by means of mechanical adjustment to the vacuum nozzle.

Filling is achieved when empty bottles are placed on a platform under the vacuum nozzle which when inserted into the neck of the bottle, creates a seal. Liquid is then drawn into the container by means of a vacuum until the required fill level is reached. Any excess liquid is drawn off into a reclaim flask, when the overflow vent is reached.